

ITEM NO.	PART NUMBER	DESCRIPTION	QTY.	PRICE EACH
1	TS00173	SIGHT BASE	1	\$20.00
2	TS00107	WINDAGE SCREW, A2	1	\$ 3.00
3	TS00170	KNOB	1	\$ 8.00
4	TS00136	BALL, .125" DIAMETER CHROME	2	\$ 1.00
5	TS00135	ELEVATION DETENT SPRING	2	\$ 1.00
6	TS00238	LOCK BLOCK ASSEMBLY	1	\$ 8.50
7	TS00239	NUT	1	\$ 5.00
8	TS00168	DISC SPRING	1	\$ 2.00
9	TS00017	ROLL PIN	1	\$ 0.50
10	TS00116	DETENT SPRING	1	\$ 1.50
11	TS00169	STABILIZER PLUNGER	1	\$ 1.50
12	TS00174	FRONT SIGHT BASE	1	\$12.00
13	TS00142	SOCKET SET SCREW - 8-32 X .25"	1	\$ .75
14	TS00175	POST	1	\$ 5.00
15		USE ORIGINAL, CZ SCREW	1	.
16	TS00134	APERTURE - .062 DIA.	1	\$ 8.00
17	TS00131	SPRING WASHER, ELEVATION	1	\$ 2.00
18	TS00132	ELEVATION BASE	1	\$10.00
19	TS00133	DIAL	1	\$ 5.00

# Tech SIGHTS™

## ASSEMBLY INSTRUCTIONS for the TSM200CZ SIGHTS

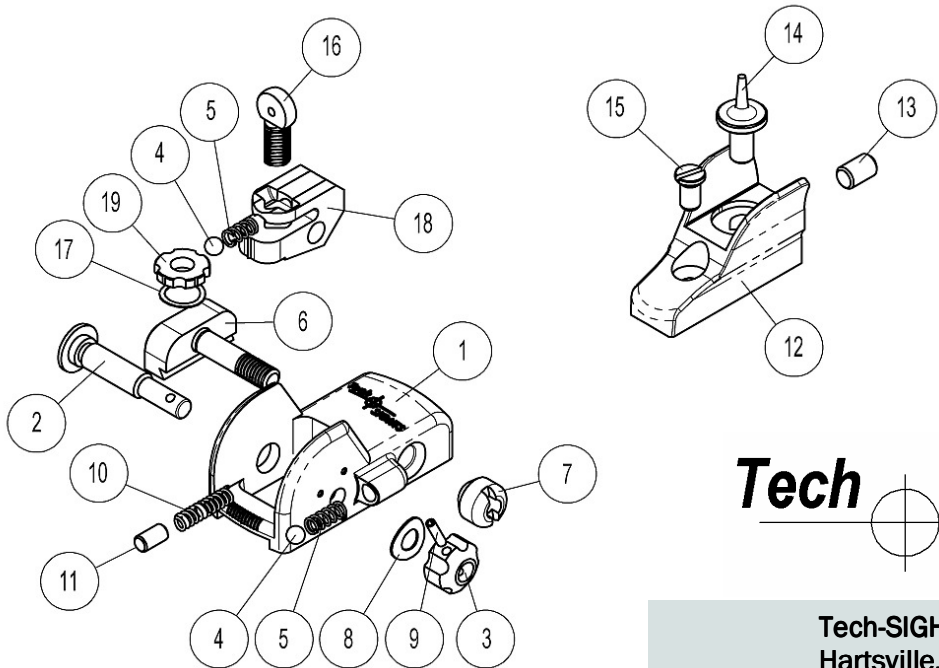

# Tech SIGHTS™

Tech-SIGHTS, LLC  
Hartsville, SC 29550

Phone: 843-332-8222  
Email: sales@Tech-SIGHTS.com  
www.Tech-SIGHTS.com

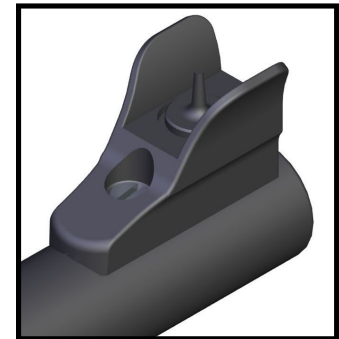
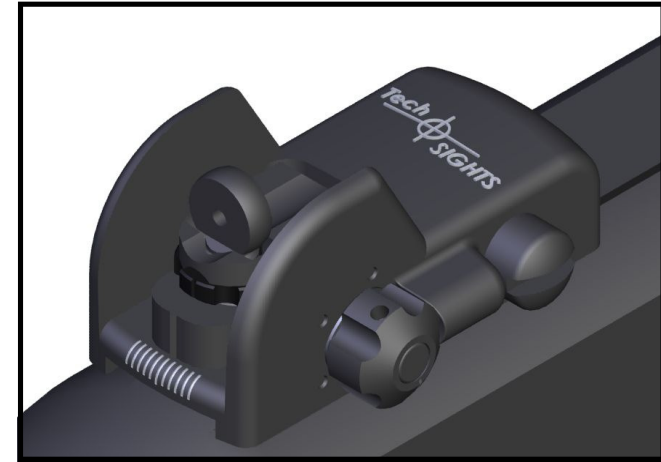

Receiver Mounted Aperture Sights  
For the  
CZ455 Scout, CZ455 Training Rifle,  
CZ455 Ultra Lux

# Tech SIGHTS™

## Assembly Instructions for the TSM200CZ Sights

**1. ALWAYS POINT MUZZLE IN A SAFE DIRECTION.**

2. Pull the bolt to the rear.

**3. CHECK TO SEE THAT THERE ARE NO CARTRIDGES IN THE CHAMBER OR MAGAZINE.**

4. Remove the original front sight from the barrel.

5. Apply Loc tite low or medium strength to the original CZ front sight screw. (Re-use the original screw).

6. Install the Front Sight Tower and tighten the CZ screw to secure it to the barrel as shown in Figure 1.

7. Apply a small amount of low to medium Loc tite to the threads on Lock Block Assembly (TS00238).

8. Position the Rear Sight Assembly on the scope rail.

9. Slide the Rear Sight Assembly to the left, engaging the right side of the scope rail.

10. Assemble the Nut (TS00239) and the Lock Block Assembly (TS00238) as shown in Figure 1.

11. Slide the Rear Sight Assembly to the desired position and tighten the nut, securing the assembly to the scope rail. (See Figure 1).

12. This completes the installation of the TSM200CZ.

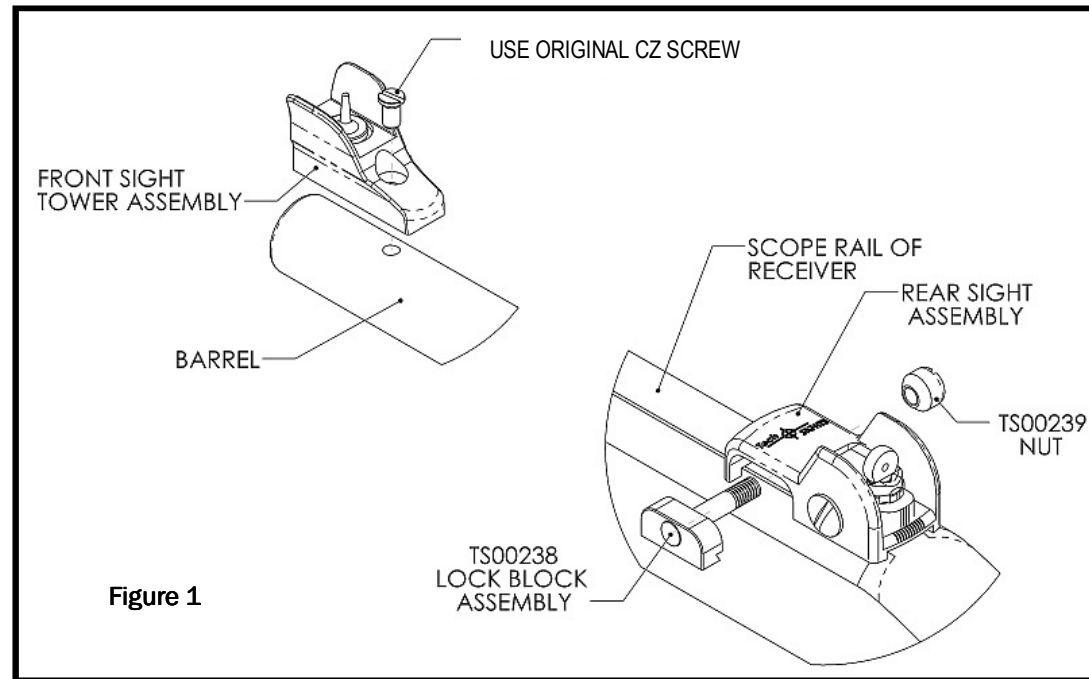
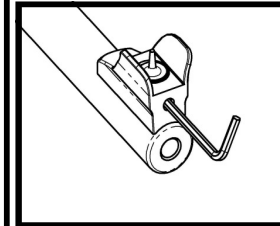

Figure 1



**Check Screw  
for tightness**

### Sight Adjustments for the TSM200CZ Sights (Figures 2&3)

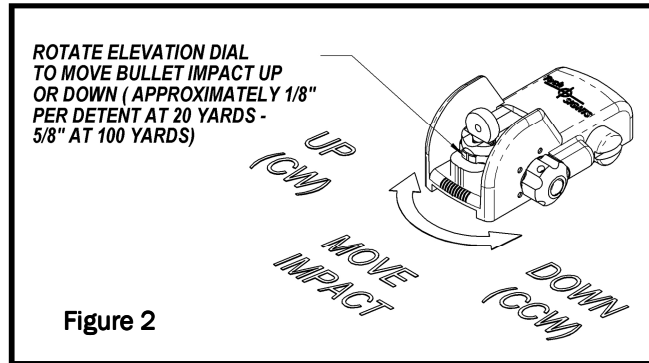

Figure 2

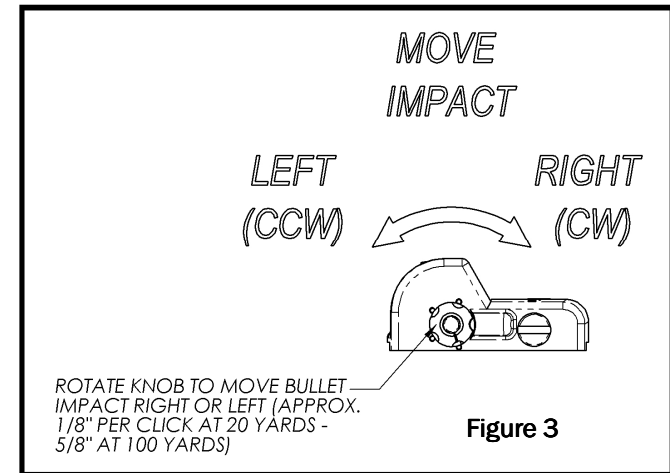

Figure 3

### PRODUCT GUARANTEE

The Tech-SIGHTS TSM200CZ has been designed to be a quality accessory for your firearm. If any part of the TSM200CZ should fail due to normal usage or manufacturing defect, we will replace the part(s) at no charge to the customer for a period of one year from the date of purchase.

The TSM200CZ gives the shooter a quality extended sighting radius aperture sight. Although we have made every effort to create a sight that will increase the accuracy of your firearm, we can make no guarantee as to the results each individual will experience using the sight.