

ITEM NO.	PART NUMBER	DESCRIPTION	QTY.	PRICE EACH
1	TS00173	SIGHT BASE	1	\$20.00
2	TS00107	WINDAGE SCREW, A2	1	\$3.00
3	TS00170	KNOB	1	\$8.00
4	TS00136	BALL, .125" DIAMETER CHROME	2	\$1.00
5	TS00135	ELEVATION DETENT SPRING	2	\$1.00
6	TS00238	LOCK BLOCK ASSEMBLY	1	\$8.50
7	TS00239	NUT	1	\$5.00
8	TS00168	DISC SPRING	1	\$2.00
9	TS00017	ROLL PIN	1	\$.50
10	TS00116	DETENT SPRING	1	\$1.50
11	TS00169	STABILIZER PLUNGER	1	\$1.50
12	TS00134	APERTURE - .062 DIA.	1	\$8.00
13	TS00131	SPRING WASHER, ELEVATION	1	\$2.00
14	TS00132	ELEVATION BASE	1	\$10.00
15	TS00133	DIAL	1	\$5.00
16	TS00210	FRONT BLADE CZ 452	1	\$10.00
17	TS00207B	GUARD - MODIFIED	1	\$12.00
18	TS00223	SOCKET SET SCREW - 4-48 X 1/8"	1	\$1.00

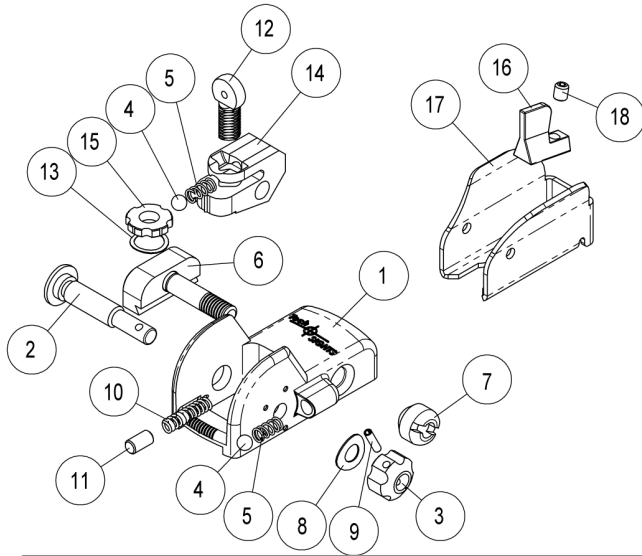

Sight Adjustments for the CZ200B Sights (Figures 1&2)

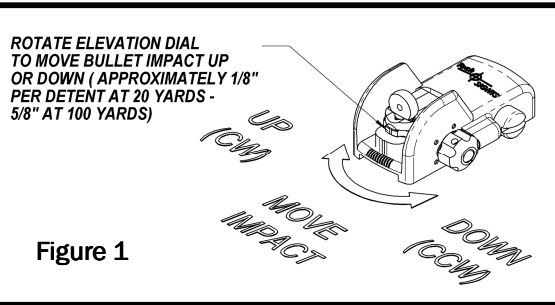

Figure 1

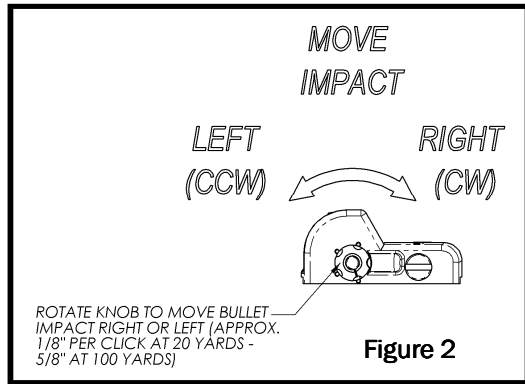

Figure 2



ASSEMBLY INSTRUCTIONS for the CZ200B SIGHTS



Receiver Mounted Aperture Sights For the CZ455 LUX & CZ455 FS

PRODUCT GUARANTEE

The Tech-SIGHTS CZ200B has been designed to be a quality accessory for your firearm. If any part of the CZ200B should fail due to normal usage or manufacturing defect, we will replace the part(s) at no charge to the customer for a period of one year from the date of purchase.

The CZ200B gives the shooter a quality extended sighting radius aperture sight. Although we have made every effort to create a sight that will increase the accuracy of your firearm, we can make no guarantee as to the results each individual will experience using the sight.



Tech-SIGHTS, LLC
Hartsville, SC 29550

Phone: 843-332-8222
Email: sales@Tech-SIGHTS.com
www.Tech-SIGHTS.com

Tech SIGHTS™

Assembly Instructions for the CZ200B Sights

1. ALWAYS POINT MUZZLE IN A SAFE DIRECTION.

2. Pull the bolt to the rear.

**3. CHECK TO SEE THAT THERE ARE NO CARTRIDGES
IN THE CHAMBER OR MAGAZINE.**

4. Remove the original front sight hood from the rifle as shown in Figure 1. A drop of oil on the grooves on each side of the sight base should help to make removal easier.

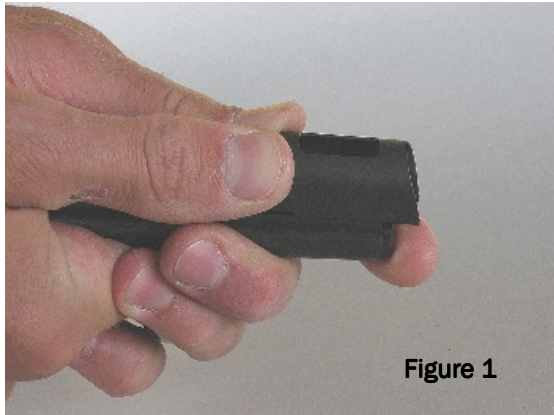

Figure 1

5. Remove the original sight blade as shown in Fig. 2.



Figure 2

6. Apply a medium strength thread lock compound on the front sight set screw. Thread the set screw into the taller front sight blade supplied with the sight and slide it into the sight ramp as shown in Figure 3. Slide the blade approx half way up the ramp and snug the set screw with the .050 hex key. Do not over tighten the screw.



Figure 3

7. Place a light coat of grease or oil in the grooves on each side of the sight ramp. Start one side of the sight guard in the groove (as shown in Figure 4) and spread the sight guard by pulling the other side of the guard until it will start in the groove on the other sight of the sight ramp base (Figure 5). Once both sides are started into the grooves, push the guard all the way on the sight ramp base until it snaps in place as shown in Figs. 6 & 7.



Figure 4



Figure 5



Figure 6



Figure 7

8. Remove the nut and lock block assembly from the rear sight assembly and apply medium strength thread locker on the threaded hole in the nut and the threads of the lock block assembly. Reassemble the screw and lock block to the rear sight assembly.

9. Loosen the nut far enough to allow the rear sight assembly to fit over the scope rail on the top of the rifle's receiver as shown in Figures 8 & 9. Position the sight on the rail as shown so that the bolt handle will clear and tighten the nut as shown in Figure 9.



Figure 8



Figure 9

10. This completes the installation of the CZ200B sighting system.