

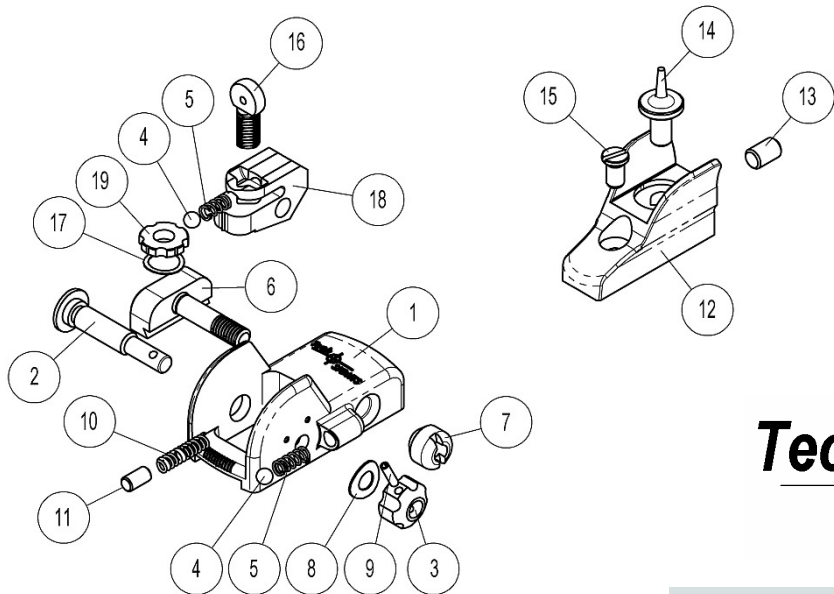

ITEM NO.	PART NUMBER	DESCRIPTION	QTY.	PRICE EACH
1	TS00173	SIGHT BASE	1	\$20.00
2	TS00107	WINDAGE SCREW, A2	1	\$3.00
3	TS00170	KNOB	1	\$8.00
4	TS00136	BALL, .125" DIAMETER CHROME	2	\$1.00
5	TS00135	ELEVATION DETENT SPRING	2	\$1.00
6	TS00238	LOCK BLOCK ASSEMBLY	1	\$8.50
7	TS00239	NUT	1	\$5.00
8	TS00168	DISC SPRING	1	\$2.00
9	TS00017	ROLL PIN	1	\$.50
10	TS00116	DETENT SPRING	1	\$1.50
11	TS00169	STABILIZER PLUNGER	1	\$1.50
12	TS00174	FRONT SIGHT BASE	1	\$12.00
13	TS00142	SOCKET SET SCREW - 8-32 X .25"	1	\$.75
14	TS00175	POST	1	\$5.00
15	TS00205	SCREW, 6-48	1	\$2.00
16	TS00134	APERTURE - .062 DIA.	1	\$8.00
17	TS00131	SPRING WASHER, ELEVATION	1	\$2.00
18	TS00132	ELEVATION BASE	1	\$10.00
19	TS00133	DIAL	1	\$5.00

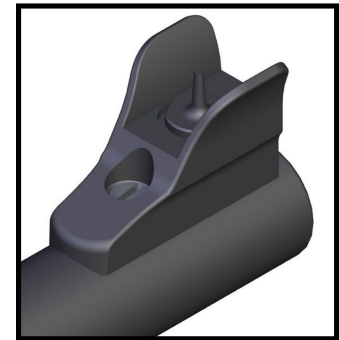
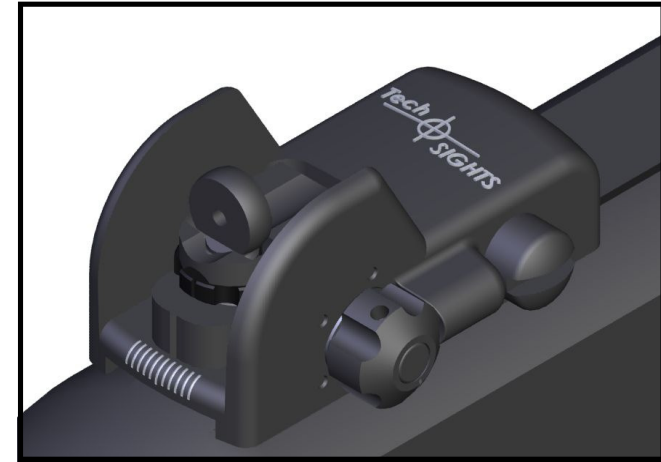

**Tech**  **SIGHTS**<sup>TM</sup>

**ASSEMBLY INSTRUCTIONS**  
for the  
**MOS200 SIGHTS**



**Tech**  **SIGHTS**<sup>TM</sup>

**Tech-SIGHTS, LLC**  
**Hartsville, SC 29550**

Phone: 843-332-8222  
Email: sales@Tech-SIGHTS.com  
www.Tech-SIGHTS.com

**Receiver Mounted Aperture Sights**  
**For the Mossberg 702**

# Tech SIGHTS™

## Assembly Instructions for the MOS200 Sights

**1. ALWAYS POINT MUZZLE IN A SAFE DIRECTION.**

2. Pull the bolt to the rear.

**3. CHECK TO SEE THAT THERE ARE NO CARTRIDGES IN THE CHAMBER OR MAGAZINE.**

4. Remove the original front sight from the barrel.

5. Apply Loc tite low or medium strength to the 6-48 screw.

6. Install the Front Sight Tower and tighten the 6-48 screw to secure it to the barrel as shown in Figure 1.

7. Apply a small amount of low to medium Loc tite to the threads on the nut and also threads on the lock block assembly.

8. Position the Rear Sight Assembly on the scope rail.

9. Slide the Rear Sight Assembly to the left, engaging the right side of the scope rail.

10. Assemble the nut and the lock block assembly as shown in Figure 1.

11. Slide the Rear Sight Assembly to the desired position and tighten the nut, securing the assembly to the scope rail. (See Figure 1).

12. This completes the installation of the MOS200.

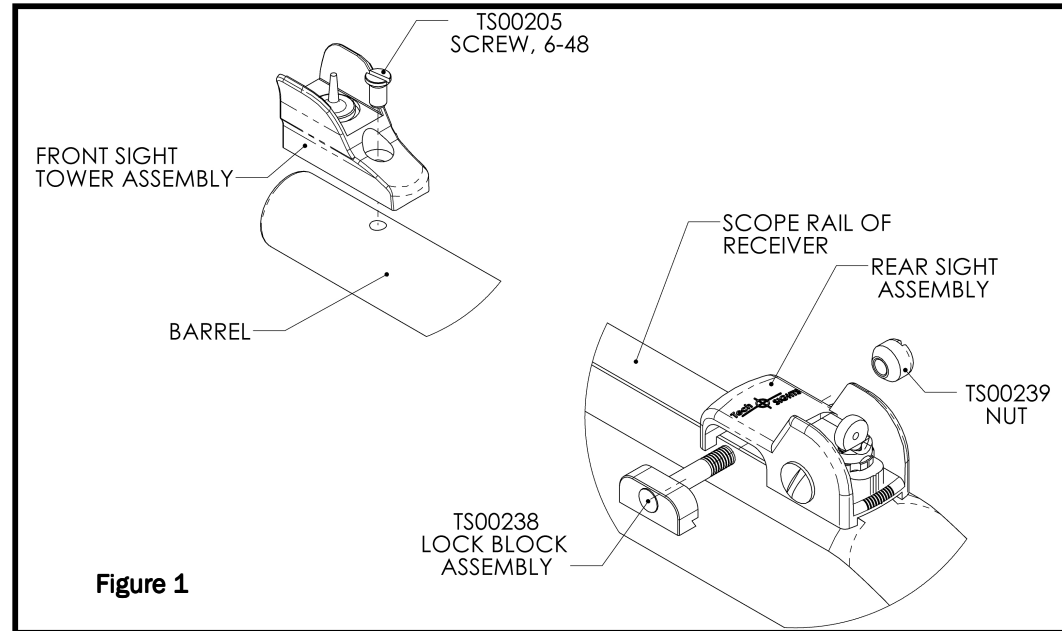
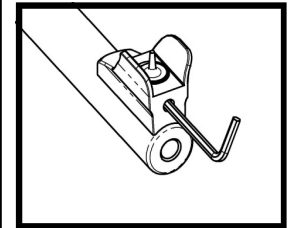

Figure 1



**Check Screw  
for tightness**

## Sight Adjustments for the MOS200 Sights (Figures 2&3)

ROTATE ELEVATION DIAL  
TO MOVE BULLET IMPACT UP  
OR DOWN (APPROXIMATELY 1/8"  
PER DETENT AT 20 YARDS -  
5/8" AT 100 YARDS)

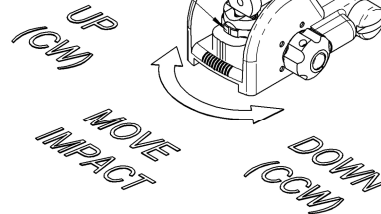
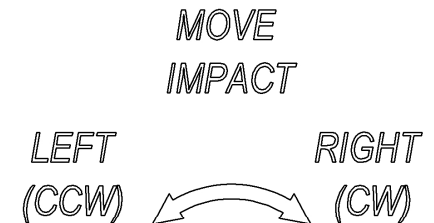

Figure 2



ROTATE KNOB TO MOVE BULLET  
IMPACT RIGHT OR LEFT (APPROX.  
1/8" PER CLICK AT 20 YARDS -  
5/8" AT 100 YARDS)

Figure 3

### PRODUCT GUARANTEE

The Tech-SIGHTS MOS200 has been designed to be a quality accessory for your firearm. If any part of the MOS200 should fail due to normal usage or manufacturing defect, we will replace the part(s) at no charge to the customer for a period of one year from the date of purchase.

The MOS200 gives the shooter a quality extended sighting radius aperture sight. Although we have made every effort to create a sight that will increase the accuracy of your firearm, we can make no guarantee as to the results each individual will experience using the sight.