

TSR100 & TSR200 PARTS

ITEM NO.	PART No.	DESCRIPTION	QTY.	PRICE EACH
1	TS00138	SIGHT BASE	1	\$20.00
2	TS00107	WINDAGE SCREW	1	\$ 3.00
3	TS00106	APERTURE SPRING	1	\$ 1.50
4	TS00108	WINDAGE DRUM	1	\$ 4.00
5	TS00019	SPRING WASHER	1	\$ 2.50
6	TS00002	REAR SIGHT DETENT	1	\$ 1.00
7	TS00116	DETENT SPRING	1	\$ 1.50
8	TS00017	ROLL PIN	1	\$.50
9	TS00143	SCREW, 6-48	2	\$ 2.00
10	TS00132	ELEVATION BASE	1	\$10.00
11	TS00133	DIAL	1	\$ 5.00
12	TS00136	BALL	1	\$.50
13	TS00134	APERTURE - .062 DIA.	1	\$ 8.00
14	TS00131	SPRING WASHER, ELEVATION	1	\$ 2.00
15	TS00135	ELEVATION DETENT SPRING	1	\$ 1.00
16	TS00139_09	SIGHT TOWER	1	\$12.00
17	TS00216	BUTTON HEAD SCREW 6-32 X 1/8"	2	\$ 2.00
18	TS00215	STOP WASHER	2	\$ 1.00
19	TS00217	SOCKET SET SCREW - 10-32 X 1/4" FLAT POINT	1	\$ 1.00
20	TS00137	DETENT	1	\$ 1.50
21	TS00141	ELEVATION DETENT SPRING	1	\$ 1.00
22	TS00140	FRONT POST - .045 (TSR100)	1	\$ 5.00
23	TS00182	FRONT POST - EXTENDED .045 (TSR200)	1	\$ 5.00
24	TS00109	REAR SIGHT APERTURE	1	\$ 8.00

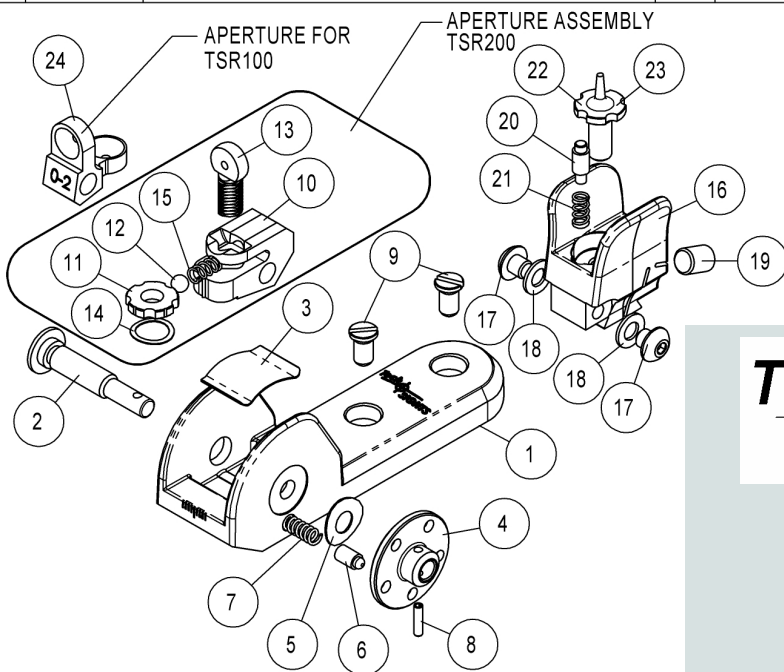
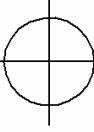

Tech TM  **SIGHTS**

Precision Shooting Accessories

INSTRUCTIONS for the TSR100 & TSR200 SIGHT



Receiver Mounted Aperture Sight
For the Ruger® 10/22

Tech TM  **SIGHTS**

Tech-SIGHTS, LLC
904 Deer Run Drive
Hartsville, SC 29550

Phone: 843-332-8222
Email: sales@Tech-SIGHTS.com
www.Tech-SIGHTS.com

Tech TM SIGHTS

Assembly Instructions for the TSR100 & TSR200 Sight

1. Remove the magazine from the rifle.
2. Check the chamber to make sure that it is empty. Work the action until you can visually confirm that there are no cartridges in the chamber and that it is empty.
3. Secure the barrel just below the front sight. Be sure to support the whole rifle so as not to bend the barrel.
4. Use a brass punch to tap on the base of the front sight. Drive the front sight blade out of the dovetail slot from left to right. (See Figure 1)

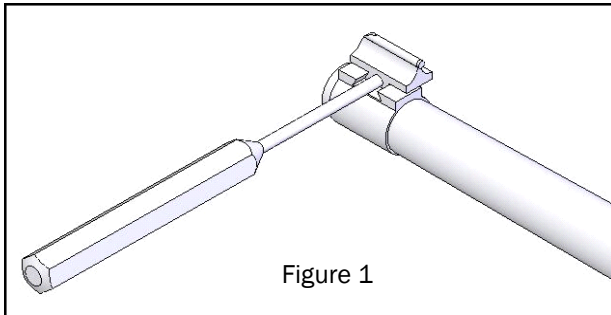

Figure 1

5. Remove the two button head screws (TS00216) and stop washers (TS00215) from the sight tower, if they are assembled on the tower. (See Figure 2)

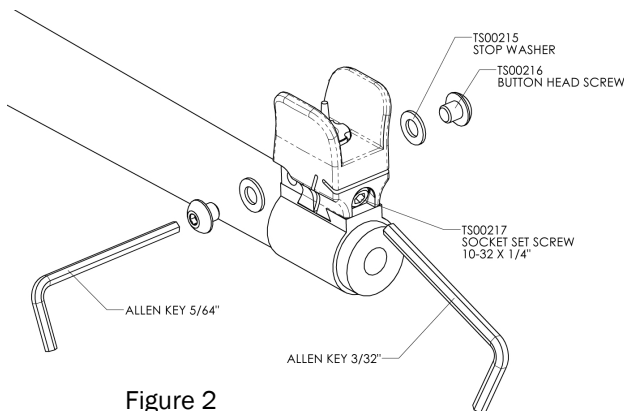

Figure 2

6. Apply a small amount of medium strength loc-tite (blue) to the 10-32 socket set screw (TS00217) and thread it into the front sight tower. **DO NOT TIGHTEN BEFORE THE SIGHT TOWER IS INSTALLED IN THE DOVETAIL SLOT!**

7. Slide or tap sight tower into the dovetail slot, right to left, until it is centered on the barrel.

8. Apply a small amount of medium strength (blue) loc-tite to the button head screws. Assemble and tighten the stop washers and button head screws to the sight tower using the 5/64 allen key.

9. Tighten the 10-32 socket set screw (TS00217) with the 3/32 allen key. **DO NOT OVER TIGHTEN!**

10. Mount the Rear Sight Assembly to the receiver. Apply the same thread locker to the two 6-48 Screws supplied with the Rear Sight Assembly. Attach the Rear Sight Assembly to the receiver as shown in Figure 3. **Be careful not to over tighten the 6-48 screws. The Ruger 10/22 receiver is aluminum and may strip if the screws are over tightened.** Snug the screws checking for looseness. Once the thread locker is set, the Rear Sight Assembly will stay secure.

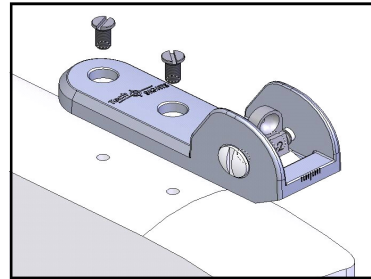
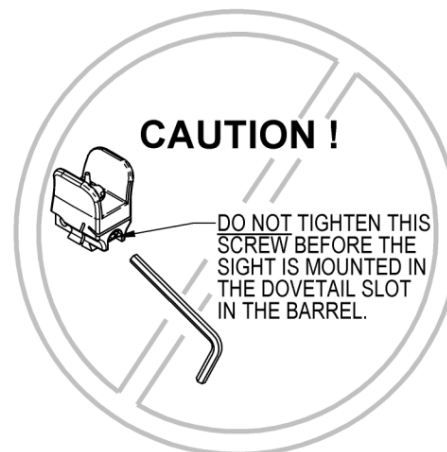

Figure 3

11. Congratulations, you have just installed the Tech-SIGHTS TSR100 or TSR200 sighting system on your rifle.



Sight Adjustment

